

**The  
Andersons**

**SSD**

**36 Inch Professional  
Drop Spreader**

# **Assembly, Use and Care**

## **Thank You!**

You have purchased the highest quality professional drop spreader available on the market today. The SSD is the accumulation of proven performance and will provide you with years of trouble-free service. In the event you should have any questions or comments, please call our professional support staff.

Our toll-free number is **1-800-225-2639 (U.S. only)**

## **Before You Begin ...**

To assemble your new spreader, we highly recommend that you read all the instructions thoroughly, familiarize yourself with the assembly and components, and verify that all parts are included in the package.

## **You Will Need ...**

The following tools:

- 7/16" open-end wrenches  
(or adjustable wrench)
- Pliers
- Phillips head screwdriver
- Grease gun

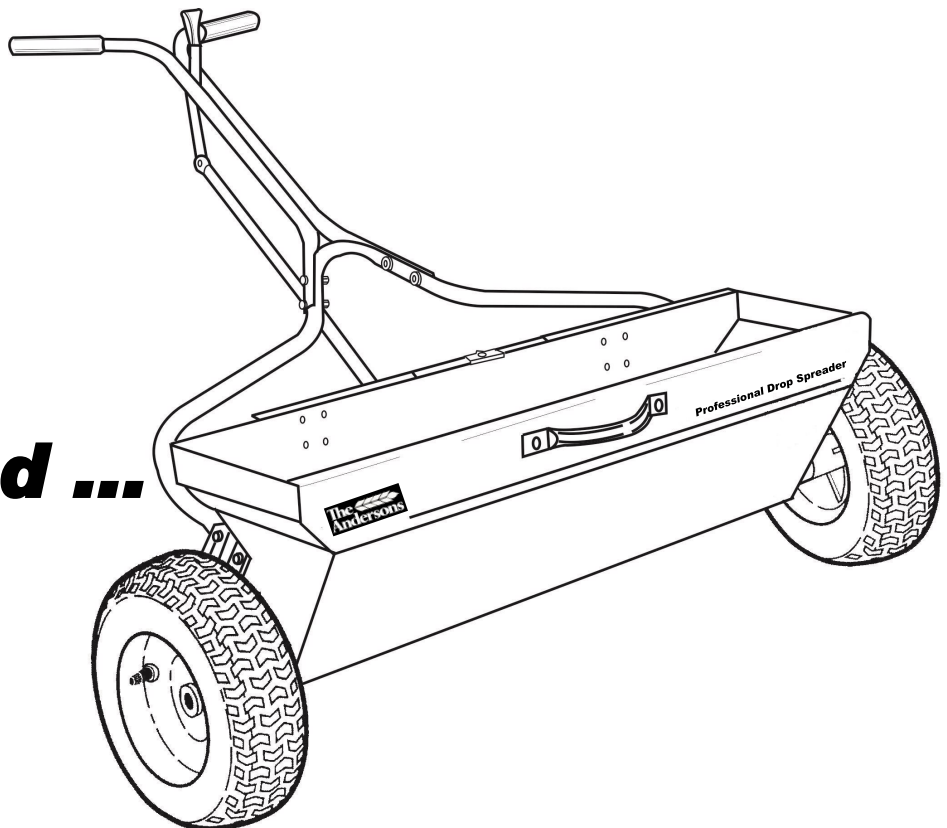

# Assembly

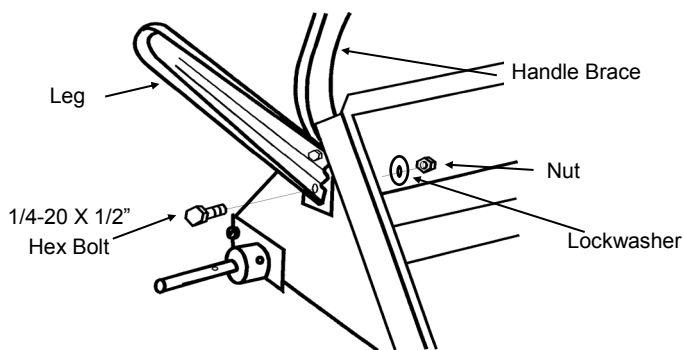

- 1)** Remove spreader and components from carton. Place Hopper on it's front panel, insert two (2) 1/4-20 X 1/2" Hex Head Bolts through the Leg, flattened end of Handle Brace, and holes in Hopper as shown. Install Lockwashers and Nuts **but leave them loose to ease assembly**. Repeat on opposite side.

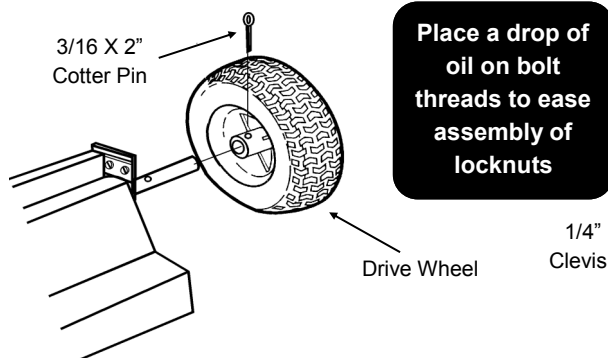

- 2)** Slide Wheels onto each end of Axle with the longer portion of the Wheel facing the Hopper. Secure Wheels with 3/16 dia. x 2" Cotter Pins.

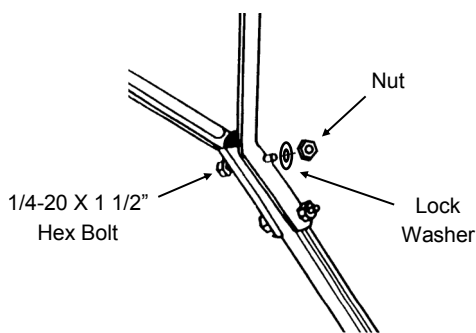

- 3)** Install Control Tube between the Control Tube Braces and secure with (2) 1/4-20 X 1/2" Hex Bolts, Lockwashers, and nuts.

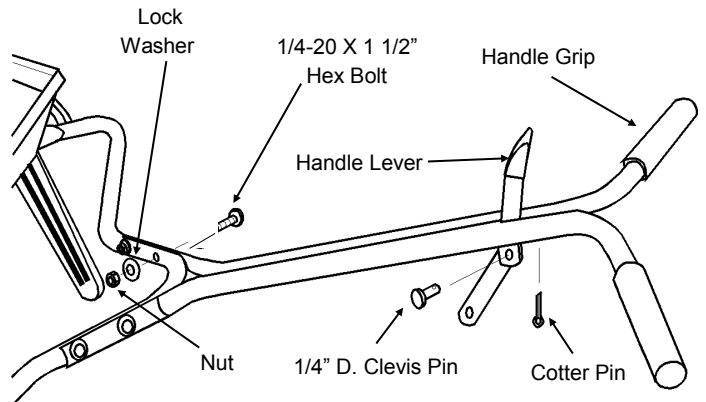

- 4)** Stand spreader upright on Wheels. Attach Upper Handle assembly to Handle Brace (make sure Handle is positioned as shown) using (4) 1/4-20 X 1/2" Hex Bolts, (4) Lock Washers, and (4) Nuts. Tighten securely. Install Handle Grips onto Upper Handle. Slide Handle Lever assembly between Handle Brackets and secure with 1/4 dia, Clevis and Cotter Pin. Make sure Lever pivots freely.

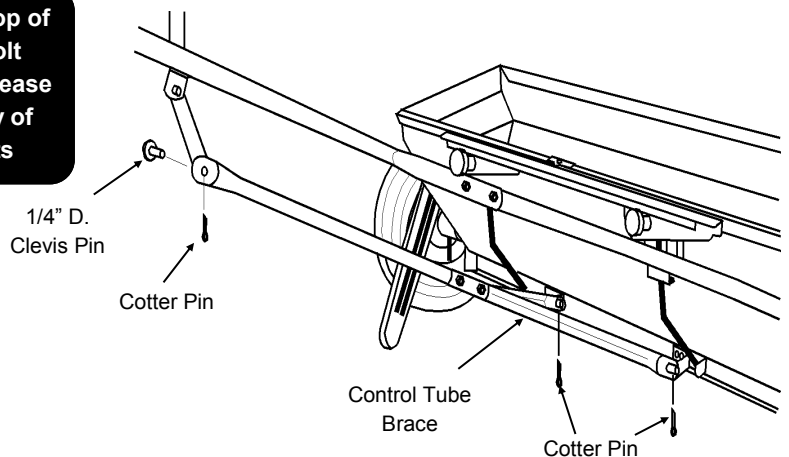

- 5)** Slide the ends of the Control Tube Braces over the Studs on the Shutoff Bar Brackets, secure with Cotter Pins. Attached opposite end of Control Tube to the Handle Lever using 1/4 dia. Clevis and Cotter Pin. Make sure Handle Lever operates freely. **Tighten all Nuts left loose in step #1**. Install Hopper Handle on front of spreader using two 1/4-20 x 1/2" Hex Bolts, Lock washers, and nuts.

- 6)** To check spreader for completed shutoff, pull the Handle Lever back to the "OFF" position. Turn spreader over to see if the Shutoff Bar completely covers the holes in the bottom of the Hopper. If not, stand the spreader upright on Wheels push the Handle Lever forward to the "ON" position. Loosen the Bolts in the Hopper holding the Handle Brace. Push down on the Handle Brace and the front of the Hopper. Retighten Bolts and check the shutoff.

# Operation

**1)** Before filling Hopper, make sure spreader Handle Lever is in the "OFF" position. Always fill spreader on walk or drive, not on the lawn.

**2)** Loosen Rate Control Knobs and move the Tie Bar to setting recommended for the product applied. If setting is not known, refer to "DETERMINING APPLICATION RATES" section of this book. Retighten knobs after setting is made.

**3)** Always push spreader, do not pull. Start spreader in motion and as it passes over the area to be treated, push Handle Lever to the "ON" position. Close Handle Lever at the end of each pass.

**4)** Operate spreader at 3 MPH pace. (33.3 feet in 7.5 seconds)

**5)** Apply two header strips at each end of area to be treated and then proceed lengthwise between the header strips. Be sure to overlap the wheel tracks slightly to prevent streaking.

**6)** When applying lime, do not use limestone that is so finely ground that it will pack inside the Hopper, or use hard, abrasive particles which will damage the spreader. Use only compacted, free flowing, non-abrasive lime products.

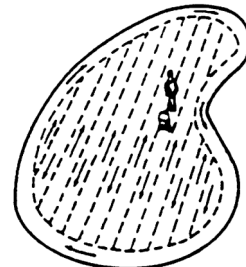
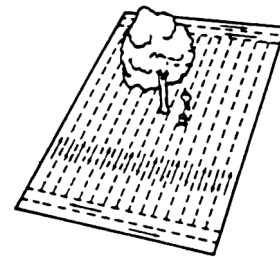

## Determining Application Rates

The following procedure provides a means of accurately determining drop spreader settings when settings do not appear on the package, or to "fine tune" the manufacturer's recommend settings. Spreader rates can vary due to walking speed, condition of turf, humidity, physical characteristics of the product being applied, or condition of the spreader. It is good practice to double check settings using the following method:

PROCEDURE	EXAMPLE
<b>1)</b> The manufacturer will recommend coverages on the product package. Generally, it is stated as applying a certain number of pounds of product per 1,000 square feet.	The contents of this package (25 lbs.) covers 2,000 square feet.
<b>2)</b> Determine the amount of material in pounds to cover 100 square feet. Add two zeros to weight of bag and divide that by the square foot coverage.	2,500 divided by 2,000 square feet = 1.25 lbs.
<b>3)</b> To change the decimal portion of answer in step #2 to ounces, multiply decimal portion by 16.	0.25 x 16 oz. = 4 oz. Total weight = 1 lb.- 4 oz.
<b>4)</b> On a clean walk of driveway, measure out 33.3 feet- the distance required to cover 100 square feet.	
<b>5)</b> Add a measured amount of product to the spreader- 2 to 3 times the recommended rate. Operate spreader at a brisk walking speed (3 mph of 33.3 feet in 5. sec.) over the measured distance. Empty the spreader and weigh the amount left. Compare with the beginning amount; the difference is the amount applied. Adjust the setting up or down to achieve the correct application rate.	

## Maintenance

- 1)** Never store unused material in spreader. Return unused product to its original container.
- 2)** Set Rate Slide on the highest number, open spreader and spin Wheels to remove excess material.
- 3)** Wash out Hopper thoroughly after each use to remove material clinging to surfaces. Pay close attention to area between the Shutoff Bar and Hopper. Allow spreader to completely dry.
- 4)** Oil bottom of Hopper, Control Housing Spring and Agitators at the Center Bearing. Lubricate Axle Bearings with grease. Store spreader in open position.

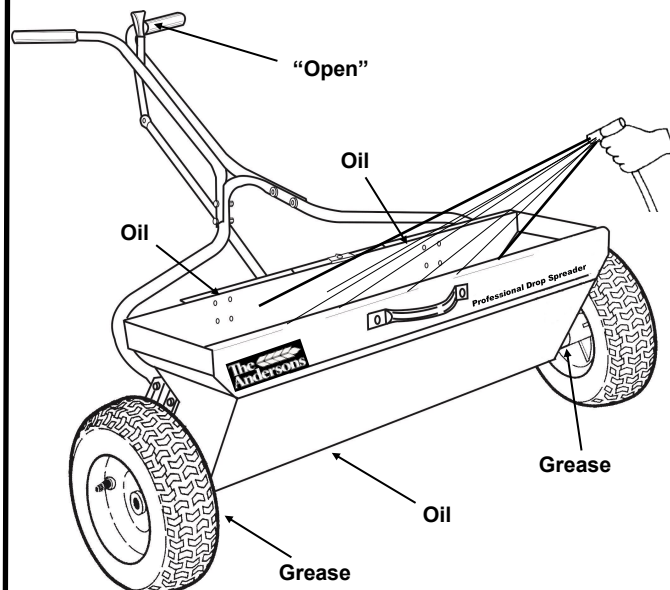

# Parts Diagram - SSD

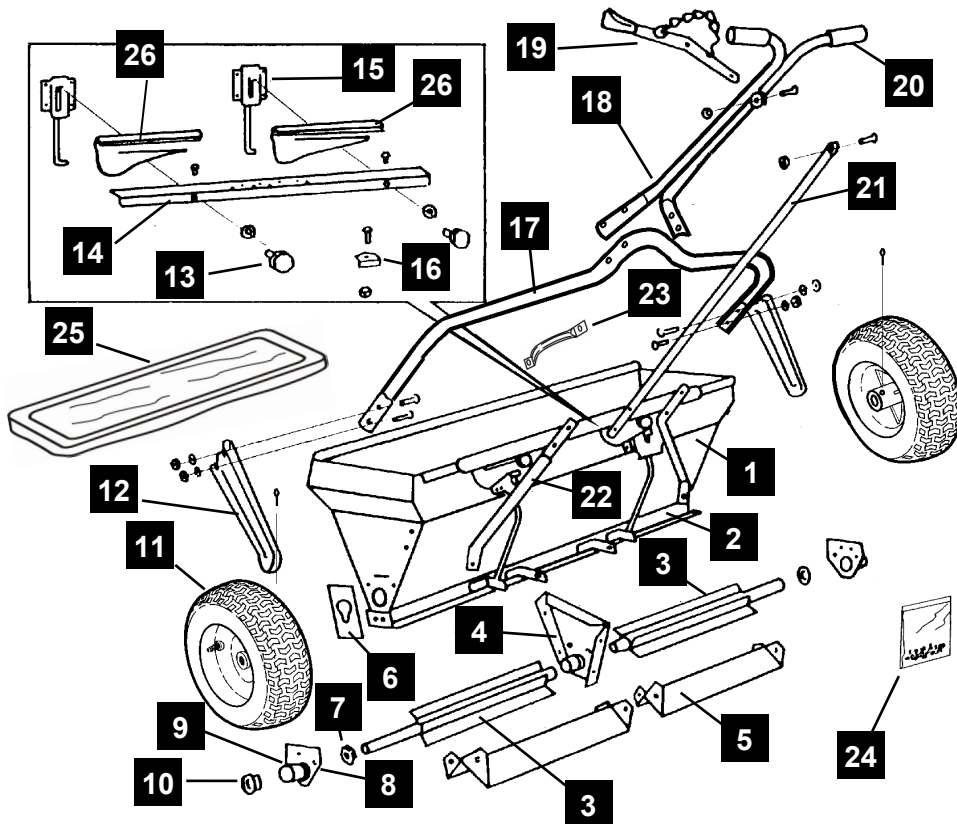

## Parts List

KEY	PART #	DESCRIPTION
1	14475-1	HOPPER ASSEMBLY
2	14479-1	SHUTOFF BAR ASSEMBLY
3	14228-1	AGITATOR/AXLE ASSEMBLY-LH. & RH
4	14231	BEARING SUPPORT ASSEMBLY
5	14235	AGITATOR BAFFLE
6	14227	END HANGER
7	14007	AXLE GREASE SEAL
8	14222-1	PLATE ASSEMBLY-BEARING END
9	90005	GREASE FITTING
10	14006	AXLE BEARING
11	15043	WHEEL & TIRE ASSEMBLY
12	12714	LEG
13	12704	RATE CONTROL KNOB
14	14237	TIE BAR
15	14286	SPRING HOUSING ASSEMBLY
16	12708	POINTER
17	15029-1	HANDLE BRACE
18	15046	UPPER HANDLE ASSEMBLY
19	14047	HANDLE LEVER ASSEMBLY W/ CHAIN
20	14870	HANDLE GRIP (set of 2)
21	14415-1	CONTROL TUBE
22	14409	CONTROL TUBE BRACE
23	15048	HOPPER LIFT HANDLE
24	14242-3	FASTENER PACKAGE
25	14493-1	HOPPER COVER
26	14236	RATE PLATE

## Ordering Parts

Extra parts may be obtained at current prices, be sure to include:

- 1) Spreader model number (ASP8008)
- 2) Spreader model name (SSD)
- 3) Part number
- 4) Description of part (refer to list)

Call 1-800-294-0671 to order parts. (Note: Sales of parts for Andersons spreaders are handled by EarthWay.)



For More  
Information  
Call . . .

**1-800-225-2639**

(U.S. Only)

The Andersons' toll-free Helpline. This helpline is provided to give you more information about Andersons Turf Products.



Or Visit Our  
Website At ...

[www.andersonsturf.com](http://www.andersonsturf.com)

**The Andersons**®

The Andersons, Inc.  
480 Dussel Drive  
Maumee, OH 43537  
U.S.A.

# HOW TO VERIFY SPREADER CALIBRATION

1) Loosen both rate control knobs and set spreader setting at #4 1/2. With the operating lever in the open position, turn spreader up side down.

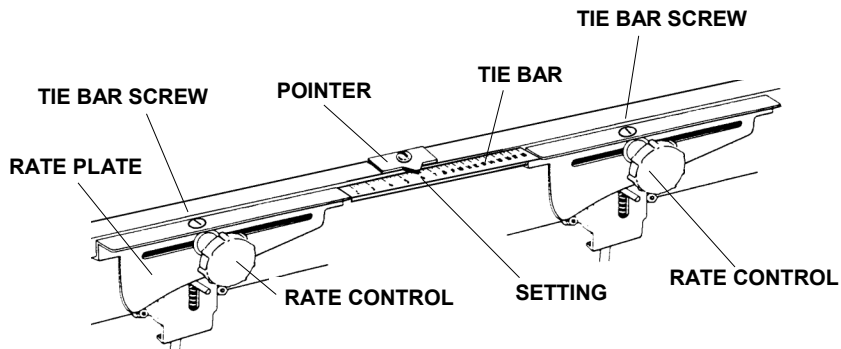
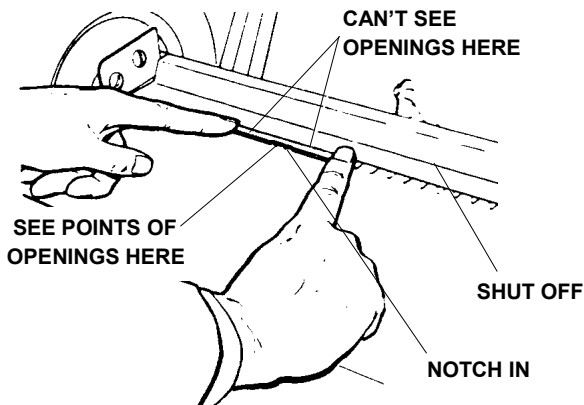

2) Place accuracy gauge in position as shown with notch facing away from shut off bar. Check openings near the ends and in the middle of the spreader. Calibration is correct when you see the points of the opening in the center of the gauge, but do not see any portion of the openings on either side of the center section. If calibration is not correct, continue to next section.

# HOW TO ADJUST SPREADER CALIBRATION

1) IF OPENINGS ARE EVEN ALL THE WAY ACROSS THE HOPPER as shown below, but the openings are too large or small, loosen both rate control knobs and move the rate plates to close or widen the openings using the accuracy gauge until calibration is correct. Retighten rate control knobs.



2) Turn spreader upright. Loosen pointer screw and align pointer at setting #4 1/2. Tighten pointer screw.

1) IF OPENINGS ARE WIDER ON ONE END OF THE SPREADER AS COMPARED TO THE OPPOSITE END as shown below, loosen both rate control knobs and the two tie bar screws (do not remove screws).

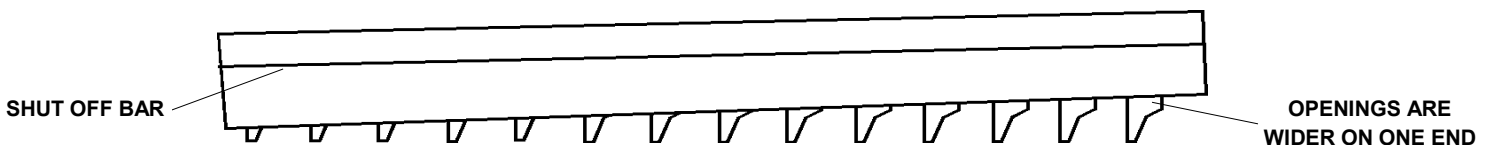

2) Working on one end of the spreader, move the rate plate closest to that end to adjust the opening using the accuracy gauge until calibration is correct. Repeat on opposite end. Check entire length and adjust rate plates as required to assure spreader is in calibration. Retighten rate control knobs.

3) Turn spreader upright and move tie bar so setting #4 1/2 is aligned with the pointer. Retighten tie bar screws.





# Warranty

---

## The Andersons warrants to Purchaser the following:

1. Product will be free of defects in materials and workmanship for a period of one year from date of purchase.
2. If the spreader is used for commercial rental the Limited Warranty shall be limited to a period of 90 days.
3. All Unit and part replacement will be performed at the reasonable discretion of The Andersons and EarthWay.
4. Labor charges are not covered and the unit need not be returned to the dealer for warranty service.
5. Proof of purchase must be supplied to The Andersons.
6. For warranty questions, contact EarthWay at 1-800-294-0671.

The Andersons sole obligation under this warranty is limited to repairing or replacing the defective part.

This warranty does not extend to any Product or parts thereof that have been allowed to corrode, subjected to misuse, neglect, accident, or modification by anyone other than The Andersons or that have been affixed to any nonstandard accessory attachment or that have been used, stored, installed, maintained operated in violation of The Andersons instructions or standard industry practice. No agent, employee or representative of The Andersons has any authority to bind The Andersons to any affirmation, representation or warranty concerning the Product and any affirmation, representation or warranty made by any agent, employee or representative shall not be enforceable by Purchaser.

**THIS WARRANTY EXTENDS ONLY TO THE ORIGINAL PURCHASER AND IS EXPRESSLY IN LIEU OF ANY OTHER EXPRESS OR IMPLIED WARRANTIES, INCLUDING WITHOUT LIMITATION ANY IMPLIED WARRANTY OR MERCHANTABILITY OR FITNESS OR INTENDED USE FOR A PARTICULAR PURPOSE AND OF ANY OTHER OBLIGATION ON THE PART OF The Andersons. The Andersons SHALL NOT BE LIABLE FOR ANY INCIDENTAL, SPECIAL OR CONSEQUENTIAL LOSS, DAMAGE OR EXPENSE DIRECTLY OR INDIRECTLY ARISING FROM THE USE OF ANY OF THE PRODUCT INCLUDING, BUT NOT LIMITED TO, DAMAGE OR LOSS OF OTHER PROPERTY OR EQUIPMENT, LOSS OF PROFITS OR REVENUE, COST OF CAPITAL, COST OF PURCHASED OR REPLACEMENT GOODS, OR CLAIMS OF CUSTOMERS OF PURCHASER.**



It is our first priority to improve our products' quality  
and performance whenever possible.

Your comments and questions are always welcome-

Please call our Helpline: **1-800-225-2639**  
(U.S. Only)

**Or Visit Our Website At ...**

**[www.andersonspro.com](http://www.andersonspro.com)**

**The Andersons, Inc.  
480 Dussel Drive  
Maumee, OH 43537**