

200 Gallon Space Saver

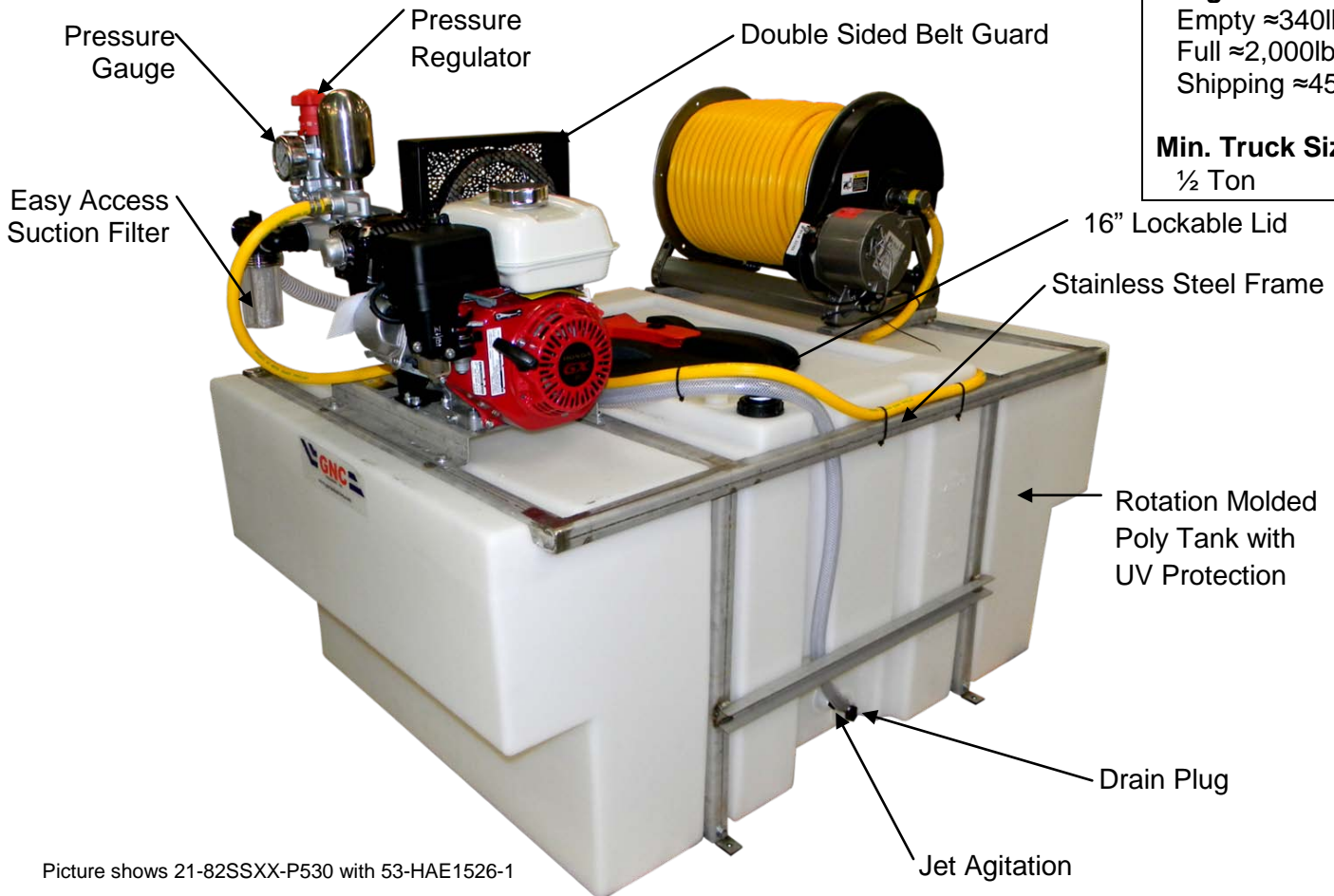

Weight:
 Empty ≈340lbs
 Full ≈2,000lbs
 Shipping ≈450lbs

Min. Truck Size:
 ½ Ton

Picture shows 21-82SSXX-P530 with 53-HAE1526-1

Base Sprayers	Pumps	Max Capacity
21-82SSXX-P530	Piston	10 GPM / 600PSI
21-82SSXX-KA43	Diaphragm	10 GPM / 560PSI
21-82SSXX-P550	Piston	15 GPM / 600PSI

Reel Packages	Reel	Hose
53-HA1526-0	Hannay 18" Manual	½"x300'
53-HA1526-1	Hannay 18" Manual	¾"x400'
53-HAE1526-0	Hannay 18" Electric	½"x300'
53-HAE1526-1	Hannay 18" Electric	¾"x400'

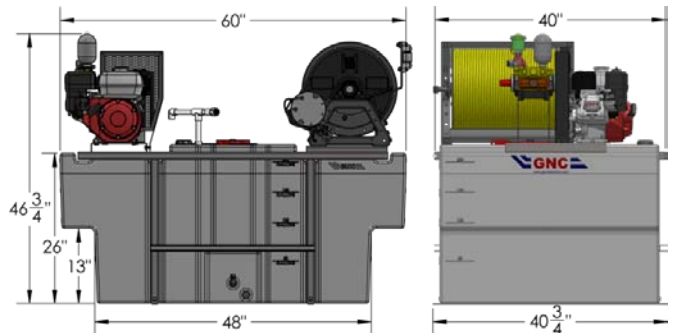

Optional Accessories	
• Honda Electric Start	• Root Feeder
• Quick Discounts	• Measuring Wheel
• Hose Roller Guides	• Ride-On Fill Kit
• Spray Guns	• Auxiliary Boom

Call for more options

Standard Features
• 200 Gallon Space Saver Tank W/ 16" Lid
• Honda GX160 Manual Start Engine
• Stainless Steel Frame
• Jet Agitation
• Easy Access Suction Filter
• Belt Guard (Piston Pump only)
• Lockable Lid (Combination Lock Included)
• Back Flow Prevention
Hose & Reels Sold Separately in Packages